

Three Stage Voltage Flicker Compensation

¹M. Roja Bharathi, ² V. Narendra Kumar

¹ (M.Tech) Student ^{1,2} Lenora College of Engineering- Rampachodavaram

² Asst.Professor Lenora College of Engineering- Rampachodavaram

Abstract - Voltage flicker is considered as one of the most severe power quality problems. Due based on voltage source converters, FACTS devices are used for voltage flicker compensation. The design and application of STATCOM technology based on voltage-source converters for voltage flicker mitigation is discussed in this paper. This paper covers the contrasting approaches; dealing with the voltage flicker mitigation in three stages and assessing the related results in details. Initially, the voltage flicker mitigation, using FCTCR (Fixed Capacitor Thyristor Controlled Reactor), was simulated. Secondly, the compensation for the Static Synchronous Compensator (STATCOM) has been performed. In this case, injection of harmonics into the system caused some problems which were later overcome by using 12-pulse assignment of SATCOM and RLC filters. The obtained results show that STATCOM is very efficient and effective for the flicker compensation. All the simulations have been performed on the MATLAB Software.

Keywords - Power Quality, Voltage Flicker, Static Synchronous Compensator (STATCOM).

1. Introduction

The relationship between power quality and distribution system has been a subject of interest for several years. The concept of power quality describes the quality of the supplier voltage in relation to the transient breaks, falling voltage, harmonics and voltage flicker [1]. Voltage Flicker is the disturbance of lightning induced by voltage fluctuations. Very small variations are enough to induce lightning disturbance for human eye for a standard 230V, 60W coiled-coil filament lamp. The disturbance becomes perceptible for voltage variation frequency of 10 Hz and relative magnitude of 0.26% [1-2]. Huge non-linear industrial loads such as the electrical arc furnaces [3-4], pumps, welding machines, rolling mills and others are known as flicker generators. In this respect, the quality of supplied voltage is significantly reduced in an electrical power system and the oscillation of supplied voltage appears to be a major problem. Electric arc furnace, the main generator of voltage flicker, behaves in the form of a

constant reactance and a variable resistance. The transformer-reactance system is modeled as a lumped reactance, a furnace reactance (included connection cables and busses) and a variable resistance [5] which models the arc. Connecting this type of load to the network produces voltage variation at the common point of supply to other consumers. The relative voltage drop is expressed by equation(1):

$$\frac{\Delta U}{U_n} = \frac{R\Delta P + X\Delta Q}{U_n^2} \quad (1)$$

where ΔP and ΔQ are the variation in active and reactive power; U_n is the nominal voltage and R and X are short circuit resistance and reactance. Since R is usually very small in comparison to X , ΔU is proportional to Q (reactive power).

Therefore, voltage flicker mitigation depends on reactive power control [5]. Two types of structures can be used for the compensation of the reactive power fluctuations that cause the voltage drop:

A: shunt structure [1, 5-14]: in this type of compensation, the reactive power consumed by the compensator is kept constant at a sufficient value.

B: series structure [15-16]: in this type, all the efforts are done to decrease the voltage drop mentioned above, and finally the reactive power is kept constant despite the load fluctuations by controlling the line reactance.

In addition to the aforesaid procedures for the compensators, the active filters are used for the voltage flickers mitigation as well [17]. Furthermore, the mitigating devices based on Static VAR Compensator (SVC) such as Thyristor Switched Capacitor TSC [18], Thyristor Controlled Reactor (TCR) [19], and FCTCR [20], are the most frequently used devices for reduction in the voltage flicking. SVC devices achieved an acceptable

level of mitigation, but because of their complicated control algorithms, they have problems such as injecting a large amount of current harmonics to the system and causing spikes in voltage waveforms. Advent of FACTS devices make them ideal for use in a power system and especially in the voltage flicker mitigation. In this respect, the FACTS devices based on voltage-source converters have been able to improve the problems related to SVC [5].

A new technique based on a novel control algorithm, which extracts the voltage disturbance to suppress the voltage flicker, is presented in this paper. The technique is to use STATCOM [21-22] for voltage flicker compensation to overcome the aforementioned problems related to other techniques. The concept of instantaneous reactive power components is used in the controlling system. A two-bus system is exploited to fulfill the investigation of the presented procedure. All the simulations are done according to the usage of MATLAB software [23]. The related compensation was performed first by FCTCR. Afterwards, a 6-pulse voltage-source converter STATCOM was used to compensate for the voltage flicker. With respect to the harmonic problem in this stage, a 12-pulse voltage-source converter STATCOM was designed to isolate load harmonics and mitigate the propagation of voltage flicker to the system in the next stage. The obtained results clearly confirmed the efficiency of the 12-pulse STATCOM to complete the voltage flicker mitigation.

2. Controlling System

The concept of instantaneous reactive power is used for the controlling system. Following this, the 3-phase voltage upon the use of the park presented by Akagi [24] has been transformed to the synchronous reference frame (Park or dq0 transformation). This transformation leads to the appearances of three instantaneous space vectors: V_d on the d-axis (real or direct axis), V_q on the q-axis (imaginary or quadrature axis) and V_0 , from the 3-phase voltage of V_a , V_b and V_c . The related equations of this transformation, expressed in the MATLAB software, are as follows:

$$V_d = \frac{2}{3} (V_a \sin(\omega t) + V_b \sin(\omega t - \frac{2\pi}{3}) + V_c \sin(\omega t + \frac{2\pi}{3})) \quad (2)$$

$$V_q = \frac{2}{3} (V_a \cos(\omega t) + V_b \cos(\omega t - \frac{2\pi}{3}) + V_c \cos(\omega t + \frac{2\pi}{3})) \quad (3)$$

$$V_0 = \frac{1}{3} (V_a + V_b + V_c) \quad (4)$$

A dynamic computation shows that the voltage oscillations in the connecting node of the flicker-generating load to the network are created by 3 vectors: real current (i_p), imaginary current (i_q) and the derivative of the real current with respect to time ($\frac{di_p}{dt}$). In general, for the complete voltage flicker dt compensation, the compensating current (i_c) regarding the currents converted to the dq0 axis is given as [3]:

where R and X are the synchronous resistance and reactance of the line and f is the correcting coefficient. The constant k is also used to eliminate the average reactive power of the network [3].

$$i_c = j(i_q + i_p \frac{R}{X} f + \frac{1}{\omega} \frac{di_p}{dt} f + k) \quad (5)$$

If the compensation current of the above equation is injected to the network, the whole voltage flicker existing in the network will be eliminated. Regarding the equation, related to the dq-transformation of the 3-phase-voltages to the instantaneous vectors, it is obvious that under the conditions of accessing an average voltage flicker, V_d and V_0 , the obtained values are close to zero and V_q is a proper value adapting to the voltage oscillation of the network. This state of the 3-phase voltage flicker is presented in the following figures (simulated in the MATLAB Simulink package):

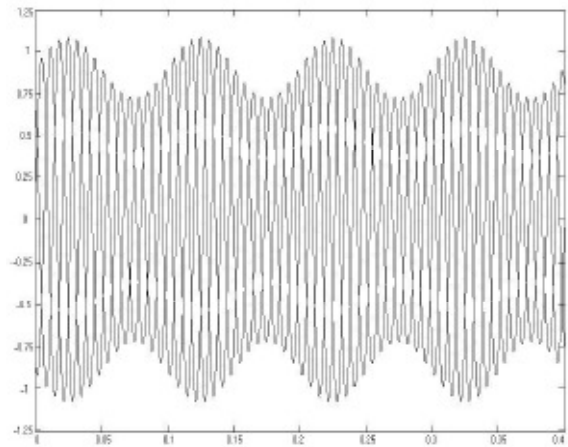

Figure 1: The voltage flicker exerted to the circuit

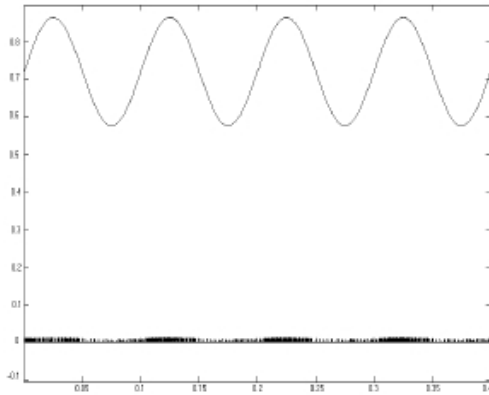

Figure 2: The instantaneous components of the 3-phase voltage flicker waveform

Then, we may conclude that the decrease of the voltage flicker of the network and the compensating control to decrease the voltage flicker can be limited only based on the amount of the imaginary component of the instantaneous voltage (V_q).

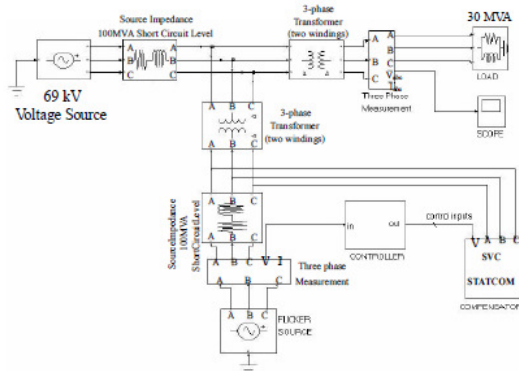

Figure 3. the studied power system

3. Compensation System

A typical two-bus power system shown in figure 3 is simulated in MATLAB for this study. It can be seen that the voltage oscillation was produced by a 3-phase flicker source connected to the main bus-bar. The complete STATCOM control system scheme implemented on MATLAB is shown in figure 4. First, using a 3-phase converter to dq0, the instantaneous vectors V_d , V_q and V_0 , are evaluated from the output 3-phase voltages whose equations were explained in the previous section. Then, from the obtained instantaneous components, sampling is taken place. Since the controlling system uses just V_q to control the STATCOM, a de-multiplexer is used to extract V_q voltage from V_d and V_0 . The obtained V_q is then entered as an input to the controlling function upon the MATLAB software. The controlling function generates the amount of conducting angle, needed for the GTOs of the STATCOM. A phase shifting block is designed to

control the appropriate phase angle of the exerting pulses upon the GTOs of the STATCOM. The outputs of this unit are entered into the STATCOM as inputs.

4. Simulation and Analysis of The Results

In order to investigate the influence of the STATCOM as an effective mitigating device for voltage flicker, three types of compensators are simulated in MATLAB. First, the voltage flicker compensation is adopted using FCTCR. Then a 6-pulse voltage-source converter STATCOM is used and finally for a complete voltage flicker mitigation a 12-pulse voltage-source converter STATCOM is designed. The compensation techniques and their results are presented in this section.

4.1 Compensation using FCTCR

In this stage a FCTCR; one of the FACTS devices being controlled by a thyristor is used to mitigate the voltage flicking. In this case, the exerted voltage flicker into the system and the compensated voltage are shown in figures 5 and 6 respectively.

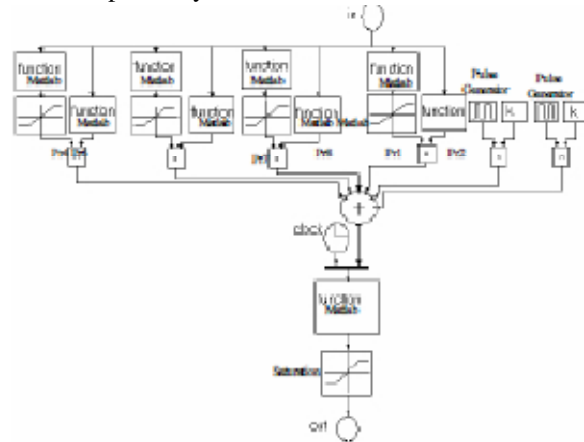

Figure 4. the controlling function, simulated upon the MATLAB Simulink

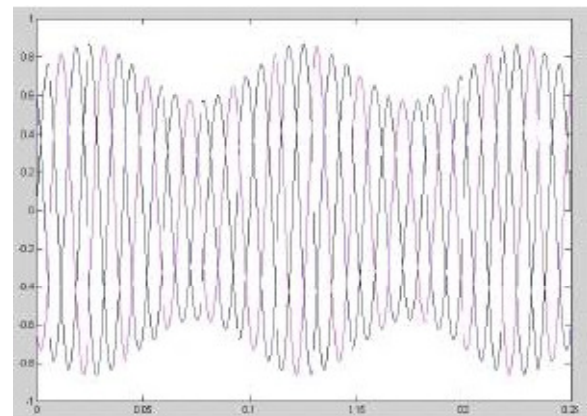

Figure 5. The generated voltage flicker by the flicker source

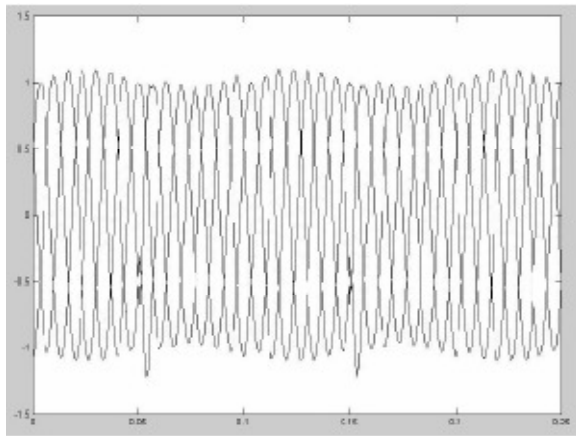

Figure 6. The compensated output voltage by FCTCR

It is obvious from the output voltage waveform controlled by FCTCR that this technique achieves a reasonable level of mitigation but is incapable to be perfectly successful. Furthermore, in spite of using a snubber circuit [25] to eliminate voltage spikes caused by the huge TCR reactor switching, there are still distortions in the output waveform.

4.2 Compensation using 6-pulse voltage-source converter STATCOM

1) The circuit diagram of a three-phase 6-pulse voltage source converter STATCOM is shown in figure 7. Six valves compose the converter and each valve is made up of a GTO with a diode connected in anti-parallel.

In this type of STATCOM, each GTO is fired and blocked one time per line voltage cycle. In this case, each GTO in a single branch is conducted during a half-cycle (180 degree) of the fundamental period.

The combined pulses of each leg have a 120 degrees phase difference to produce a balanced set of voltages. By adjusting the conducting angle of the GTOs, the generated voltage and then the injected or absorbed power of the STATCOM are controlled. In this respect, the compensated output voltage by 6-pulse voltage-source converter STATCOM is presented in figure 8.

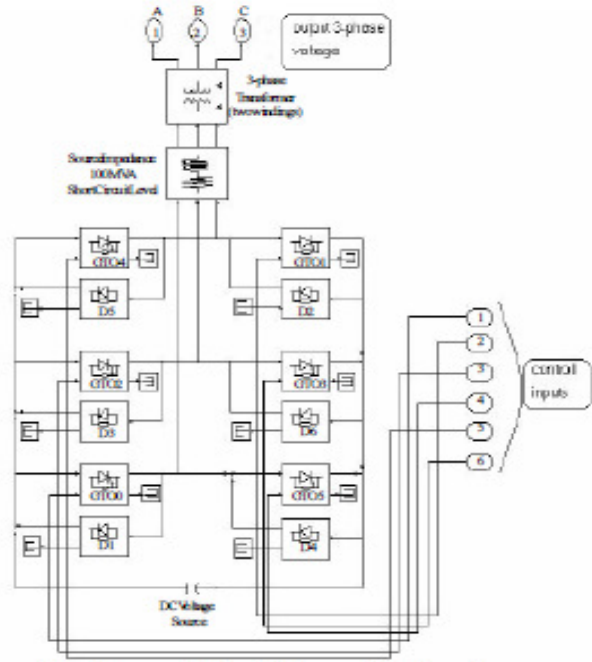

Figure 7. the circuit diagram of a 6-pulse voltage-source converter STATCOM

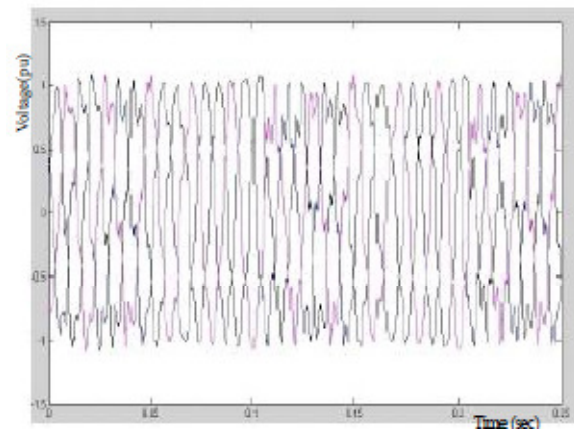

Figure 8. the compensated output voltage by 6-pulse voltage-source converter STATCOM

It can be seen that the mitigation effects of this compensator is better than that of FCTCR and effectively mitigate the voltage flicker; but the output voltage waveform has some considerable harmonics.

$$V_{ab} = \sum_{N=1,3,5}^{\infty} (4V_s/n\pi) \cos(n\pi/6) \sin n(\omega t + \pi/6) 6$$

The instantaneous output line-to-line voltage (V_{ab}) of the 6-pulse voltage-source converter is as follows:

As we see it is clearly perceptible from the above equation that, the even harmonics in the instantaneous line-to-line voltage has zero value and does not enter the network voltage.

Connecting the voltage-source converter with a wye-delta transformer to the network, multiple 3rd Harmonics (3, 9, 15 ...) are eliminated from the line voltages. Therefore, the considerable existing characteristic harmonics in the output voltage waveform in addition to the fundamental component are 5, 7, 11, 13 and higher whose values are shown in the harmonic spectrum of figure 9. It can be observed from the harmonic spectrum that 5th and 7th harmonics have considerable level comparing to the fundamental harmonics.

Furthermore, 11th and 13th harmonics are considerable which should be eliminated from the network voltage waveforms. However, higher harmonics (namely 17th, 19th and above) have values very close to zero.

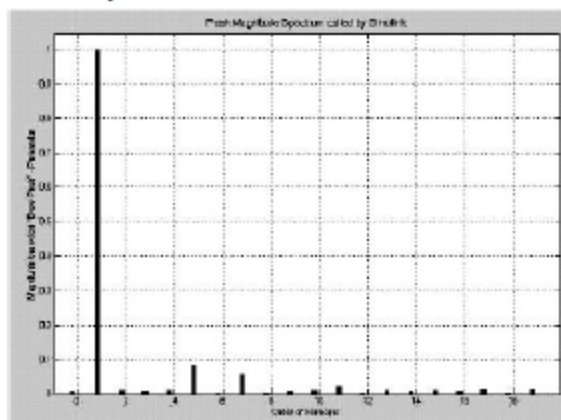

Figure 9. The harmonic spectrum of the compensated output voltage by 6-pulse voltage-source converter STATCOM

4.3 Compensation using 12-pulse Voltage-Source Converter STATCOM

In order to reduce the harmonic contents at the output voltage, the number of pulses can be increased, forming a multi-pulse configuration. Multi-pulse converters are composed by n ($n=2, 4, 8 \dots$), where n is the number of pulses. 6-pulse bridges connected in parallel on the same DC bus and interconnected in series through transformers on the AC side.

Depending on the number of pulses, these transformers and their connections can become very complex. Two 6-pulse bridges are connected, forming a 12-pulse converter for a complete voltage flicker compensation design.

In this case, the first converter is connected with a wye-wye transformer and the second one with a wye-delta transformer. These are linked together using a three winding transformer. Moreover, the delta-connected secondary of the second transformer must have 3 times the turns compared to the wye-connected secondary and the pulse train to one converter is shifted by 30 degrees with respect to the other. The 12-pulse voltage-source converter STATCOM circuit diagram is shown in figure 10.

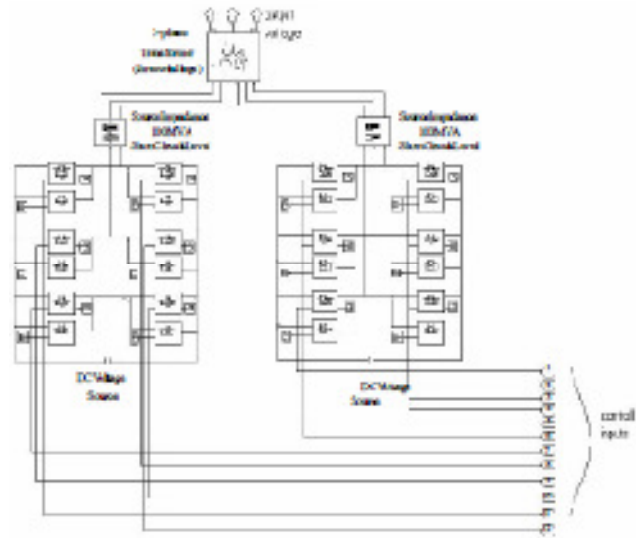

Figure 10. Circuit diagram of the 12-pulse voltage-source STATCOM configuration

The complete STATCOM control system scheme is implemented on the power system introduced in figure 3. The output voltage mitigated by 12-pulse voltage-source converter STATCOM and its harmonic spectrum are depicted in figures 11 and 12 respectively. In this respect, the voltage flicker is completely removed from the output voltage and a sinusoidal waveform is obtained. Furthermore, it is clearly obvious (from the harmonic spectrum) that almost all harmonics are removed from the output voltage. The only injected harmonics to the system are 11 and 13 that are deleted adding an RLC active filter to the designed compensator.

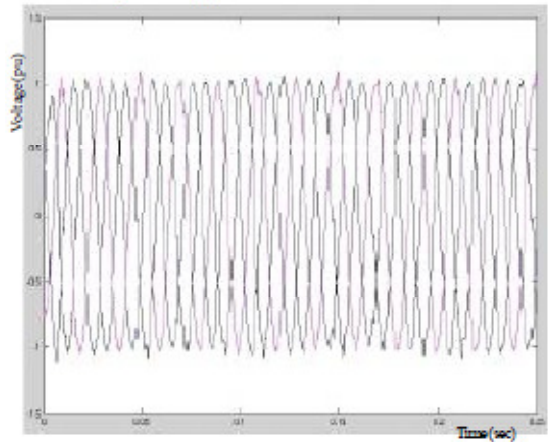

Figure 11. The output voltage mitigated by 12-pulse voltage-source converter STATCOM equipped with an RLC filter

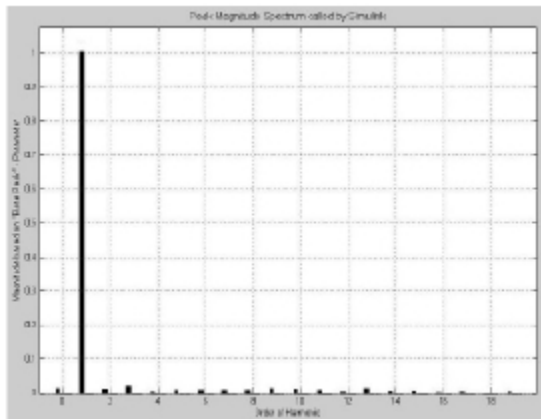

Figure 12. Harmonic spectrum of the output voltage mitigated by 12-pulse voltage-source converter STATCOM equipped with an RLC filter

5. Conclusion

The design and application of STATCOM technology based on voltage-source converters for voltage flicker mitigation is discussed in this paper. Mitigation is done in three stages and the results are compared and contrasted. First, FCTCR is used to compensate for the voltage flicker, then a 6- pulse voltage-source converter STATCOM and finally a 12- pulse STATCOM based on voltage-source converter equipped with an RLC filter are designed for complete voltage flicker compensation without harmonics. All the simulated results which have been performed in MATLAB show that a 6-pulse STATCOM is efficiently effective in decreasing the voltage flicker of the generating loads. However, there is injection of the harmonic from STATCOM into the system which can be improved with the increase of the voltage source converters of STATCOM using a 12-pulse STATCOM equipped with an RLC filter. The obtained

results clearly demonstrate that 12-pulse STATCOM equipped with an RLC filter can reduce the voltage flicker caused by nonlinear loads such as electric arc furnaces.

References

- [1] J. Sun, D. Czarkowski, Z. Zabar, "Voltage Flicker Mitigation Using PWM-Based Distribution STATCOM", IEEE Power Engineering Society Summer Meeting, Vol.1, (21-25 July 2002), pp. 616-621.
- [2] J. Mckim, "The UIE Flicker-meter Demystified", Hewlett- Packard's Power Products Division, 1997.
- [3] R. Collantes-Bellido, T. Gomez, "Identification and Modeling of a Three Phase Arc Furnace for Voltage Distribution Simulation", IEEE Trans. on Power Delivery; Vol.12, No.4, (1997), pp. 1812-1817.
- [4] L. Tang, S. Kolluri, M.F. McGranaghan, "Voltage Flicker Prediction for Two Simultaneously Operated AC Arc Furnaces" IEEE Trans. on Power Delivery; Vol.12, No.2, (1997), pp. 985-991.
- [5] M. Zouiti, S. Saadate, X. Lombard, C. Poumarede, C. Levillain, "Electronic Based Equipment for Flicker Mitigation", Proceedings of International Conference on Harmonics And Quality of Power, Vol.2, (1998), pp. 1182-1187.
- [6] T. Larsson, C. Poumarede, "STATCOM, an efficient means for flicker mitigation" IEEE Power Engineering Society Winter Meeting, Vol.2, (Jan-4Feb 1999), pp. 1208-1213.
- [7] C. S. Chen, H. J. Chuang, C. T. Hsu, S. M. Tscng, "Stochastic Voltage Flicker Analysis and Its Mitigation for Steel Industrial Power Systems", IEEE Power Tech Proceedings, Vol.1, (10-13 Sept. 2001).
- [8] Z. Zhang, N. R. Fahmi, W. T. Norris, "Flicker Analysis and Methods for Electric Arc Furnace Flicker (EAF) Mitigation (A Survey)", IEEE Power Tech Proceedings, Vol.1, (10-13 Sept. 2001).
- [9] J. R. Clouston, J. H. Gurney, "Field Demonstration of a Distribution Static Compensator Used to Mitigate Voltage Flicker", IEEE Power Engineering Society Winter Meeting, Vol.2, (31 Jan-4 Feb 1999), pp. 1138-1141.
- [10] A. Elnady, W. El-khattam, M. A. Salama, "Mitigation of AC Arc Furnace Voltage Flicker Using the Unified Power Quality Conditioner", IEEE Power Engineering Society Winter Meeting, Vol.2, (27-31 Jan. 2002), pp. 735-739.
- [11] S. Suzuki, Y. Hara, E. Masada, M. Miyatake, K. Shutoh, "Application of Unified Flow Controller for Power Quality Control at Demand Side", The Third International Power Electronics and Motion Control Conference Proceedings (PIEMC 2000), Vol.3 (15-18Aug 2000), pp. 1031-1036.
- [12] Y. Hara, E. Masada, M. Miyatake, K. Shutoh, "Application of Unified Flow Controller for Improvement of Power Quality" IEEE Power Engineering Society Winter Meeting, Vol.4, (23-27 Jan. 2000), pp. 2600-2606.
- [13] J. H. R. Enslin, "Unified Approach to Power Quality Mitigation" International Symposium on Industrial

- Electronics (ISIE '98), IEEE Proceedings, Vol.1, (July1998), pp. 8-20.
- [14] B. P. Roberts, "Power Quality Solution Alternatives for Low and Medium Voltage Continuous Process Loads", IEEE Rural Electric Power Conference, (5-7 May 2002), pp. C4-C4_7.
- [15] G. C. Montanari, M. Loggini, L. Pitti, E. Tironi, D. Zaninelli, "The effects of series inductors for flicker reduction in electric power systems supplying arc furnaces", IEEE Industry Applications Society Annual Meeting, Vol.2, (2-8 Oct. 1993), pp.1496-1503.
- [16] M. W. Marshall, "sing Series Capacitors to Mitigate Voltage Flicker Problems" IEEE Rural Electric Power Conference, (20-22 April 1997), pp. B3-1-5.
- [17] J. Dolezal, A. G. Castillo, V. Valouch, "Topologies and control of active filters for flicker compensation", International Symposium on Industrial Electronics, IEEE Proceedings, Vol.1, (4-8 Dec, 2000), pp. 90-95.
- [18] L. Gyugi, A. A. Otto, "Static Shunt Compensation for Voltage Flicker Reduction and Power Factor Correction", American Power Conference (1976), pp. 1272-1286.
- [19] Y. Hamachi, M. Takeda, "Voltage Fluctuation Suppressing System Using Thyristor Controlled Capacitors", 8th U.I.E. Congress, (1976).
- [20] F. Frank, S. Ivner, "TYCAP, Power Factor Correction Equipment Using Thyristor Controlled Capacitor for Arc Furnaces", ASEA Journal, No.46, Vol.6, (1973) pp. 147-152.
- [21] R. Mienski, R. Pawelek, I. Wasiak "Shunt Compensation for Power Quality Improvement using a STATCOM controller: Modelling and simulation", IEE Proc.-Gener. Transm. Distrib., No.2, Vol.151, (2004), pp. 274-280.
- [22] Amit K. Jain, Aman Behal, Ximing, Darren M. Dawson, Ned Mohan "Nonlinear Controller for Fast Voltage Regulation Using STATCOMs" IEEE Transaction. On control systems technology, No.6, Vol.12, (2004), pp. 827-842.
- [23] Math Works Company, 'Manual for MATLAB Simulink Software, User's Guide', 2002, Version 6.5.
- [24] H. Akagi, Y. Kanazawa, A. Nabae, "Instantaneous Reactive Power Compensator Comprising Switching Devices Without Energy Storage Components", IEEE Trans. on Industry Applications, No.3, Vol.20, (1984), pp. 625-630.
- [25] Castagnet, T., 'Is the Snubber Circuit Necessary?', STMicroelectronics, Group of Companies, Application Notes, Printed in Italy, 1999.